



**READ THIS DOCUMENT  
BEFORE INSTALLATION OR USE**



**PRODUCT REGISTRATION BY THE END USER  
IS REQUIRED FOR WARRANTY ACTIVATION**



# Owner's Manual

## RazorBack Retrofit Kit™



Rev. 1.0 / ver. RBRFK\_2024.02.08.0M



# THANK YOU

Thank you for buying an Arctic RazorBack Retrofit Kit™. As a new owner of this attachment, it is vital that you spend some quality time with this owner's manual to learn the ins and outs of this product. It is easy to follow and will enhance your ownership experience, while providing valuable information on installation, operation, safety, parts and maintenance.

To protect your investment, it is mandatory that you register your new Arctic attachment at [arcticsnowproducts.com/warranty](https://arcticsnowproducts.com/warranty) immediately. It will only take a few minutes and **only a properly pre-registered product is eligible for warranty service consideration**. Once registered, you will receive updates on product enhancements, new products, instructional videos and recalls, as well as helpful tips on operation and maintenance.

Thank you again for your recognition of excellence. You can expect your Arctic RazorBack Retrofit Kit™ to provide dependable, high quality performance for many years to come. If you have any questions, please contact us at [arcticsnowproducts.com](https://arcticsnowproducts.com) or call (815) 469-8001.

*Randy W. Strait*

Randy W. Strait  
Owner & CEO, Arctic Snow & Ice Products®



---

# TABLE OF CONTENTS

Limited Warranty Liability Statement .....	4
Warranty Information .....	5
About Arctic Snow & Ice Products .....	6
Getting to Know Your RazorBack Retrofit Kit™ .....	7
Polyblocks: What They Do & Why We Use Them .....	8
Safety Precautions & Warnings .....	9
What's Included .....	11
Razorback Retrofit Kit™ Parts List .....	12



# LIMITED WARRANTY LIABILITY STATEMENT

Working with machinery and heavy equipment is inherently dangerous with significant risk of personal injury or even death. When a customer uses machinery and heavy equipment, the customer accepts the risk inherent in that use.

The RazorBack Retrofit Kit™ are aftermarket parts; they are not genuine original equipment manufacturer (“OEM”) parts. The use of the RazorBack Retrofit Kit™ may impact the performance characteristics of or cause damage to the other systems of the equipment or vehicle. Except as described in this disclaimer, any such impact or damage is the sole responsibility of the customer and is not covered by this disclaimer.

It is the customer’s sole responsibility to inspect and verify that the dimensions, specifications, and performance of the RazorBack Retrofit Kit™ and its parts and components are appropriate for the customer’s use before any actual installation and/or use of the RazorBack Retrofit Kit™. It is the customer’s responsibility to inspect the RazorBack Retrofit Kit™ before installation for evidence of damage or defect. Improper installation can lead to personal injury or death, or property damage. Installation of the RazorBack Retrofit Kit™ should only be performed by qualified mechanics who are certified, authorized or otherwise expressly qualified to work on the vehicle and other equipment to be used with the RazorBack Retrofit Kit™ to service or maintain those vehicles and other equipment of their respective manufacturers. The customer is solely and completely responsible for determining whether its vehicle and equipment may be safely used with the RazorBack Retrofit Kit™ and that the vehicle and equipment are appropriate for this RazorBack Retrofit Kit™ and its parts and components. It is the customer’s sole responsibility to ensure that the RazorBack Retrofit Kit™ and its parts and components are properly installed on their vehicle, including any modifications deemed necessary by the customer for the proper performance of the RazorBack Retrofit Kit™.

Arctic Snow and Ice Control Products, LLC disclaims all liability for any special, direct, incidental or consequential damages, or any damages whatsoever, including, without limitation, the loss of life or limb, or damages due to bodily or personal injury, which may arise or result from the installation or use of the RazorBack Retrofit Kit™.

ANY DAMAGE RESULTING FROM A CUSTOMER’S INSTALLATION OR USE OF THE RazorBack Retrofit Kit™ AND ARCTIC SNOW AND ICE CONTROL PRODUCTS, LLC’S OTHER PRODUCTS AND PARTS IS NOT COVERED BY THIS LIMITED WARRANTY AND IS THE SOLE RESPONSIBILITY OF THE CUSTOMER. ONCE INSTALLED, THE ENTIRE RISK ARISING FROM OR OTHERWISE RELATED TO THE RazorBack Retrofit Kit™ OR OTHER PRODUCTS AND PARTS AND THEIR USE IS ASSUMED FULLY AND SOLELY BY THE CUSTOMER.

TO THE FULLEST EXTENT ALLOWED BY THE APPLICABLE STATE AND FEDERAL LAW, ARCTIC SNOW AND ICE CONTROL PRODUCTS, LLC DISCLAIMS THE IMPLIED WARRANTIES OF MERCHANTABILITY AND OF FITNESS FOR A PARTICULAR PURPOSE, EVEN IF A PARTICULAR PURPOSE IS MENTIONED HEREIN.

Arctic Snow and Ice Control Products, LLC expressly disclaims all liability for direct, indirect, special, incidental or consequential damages, including but not limited to, damage or loss of property or equipment, loss of profits or revenue, cost of purchase or replacement of goods, or claims of customers of the purchaser that result from the use of its RazorBack Retrofit Kit™, products and parts. In no event shall the liability of Arctic Snow and Ice Control Products, LLC, whether in tort, contract or otherwise, exceed the cost of the RazorBack Retrofit Kit™ or its part or component. However, the customer may have additional legal rights, which vary from state to state.

*Arctic Snow and Ice Products® is in no way endorsed by or associated with Boss Snowplow, Douglas Dynamics, Fisher Products or Western Products. The Arctic RazorBack Retrofit Kit™ is an aftermarket retrofit kit designed to work with the BOSS® EXT™, Fisher® XLS™ and the WESTERN® WIDE-OUT™ XL hardware. The Arctic Razorback Retrofit Kit™ is not endorsed by or associated with Boss Snowplow, Douglas Dynamics, Fisher Products or Western Products.*

# ARCTIC'S LIMITED 2 YEAR WARRANTY

## What is Covered

This warranty covers defects in welds and workmanship, except as set forth below, from the date of purchase.

## Who is Covered

The original purchaser from an authorized dealer.

## What You Must Do For Warranty Service

During this period, the user is responsible for informing the Dealer/Distributor of any problem(s) within 10 days of the initial occurrence. The Dealer/Distributor must then notify the manufacturer by phone or e-mail.

*Failure to fully complete the warranty registration form, with proof of purchase, within 30 days upon receipt of product will void warranty.*

## What is Not Covered

*This warranty does not cover:*

1. Failure resulting from abuse
2. Improper service
3. Misuse
4. Negligence
5. Accidental impact
6. Improper operation
7. Any design modifications
8. Any use of 3rd party wear parts
9. Wear parts (shoes, hardware, cutting edges, polyblocks)
10. Corrosion
11. Injury / Death
12. Loss of revenue or profit



To be covered under Arctic's Limited 2 Year Warranty, it is **mandatory** that you register your Arctic RazorBack Retrofit Kit.

**DO NOT FORGET TO REGISTER YOUR RAZORBACK RETROFIT KIT™.**

Register at: [arcticsnowproducts.com/warranty](http://arcticsnowproducts.com/warranty)



## LIMITED 2 YEAR WARRANTY POLICY

Manufacturer warrants the RazorBack Retrofit Kit™ to be free of defects of material and workmanship for a period of two (2) years from the date of delivery by the customer. During this period, the user is responsible for informing the Dealer/Distributor of any problem(s) within 10 days of the problem(s). The Dealer/Distributor must then notify the manufacturer by phone or e-mail. (Failure to fully complete the warranty registration form, with proof of purchase, within 30 days upon receiving a new RazorBack Retrofit Kit™ will void warranty.)

The manufacturer will not warranty any wear parts such as wear shoes, poly mounting blocks, torsion springs, hardware and cutting edges. Warranty excludes failure resulting from abusive, improper service, misuse, negligence, accidental impact,

improper operation, any design modifications and/or the use of 3rd party wear parts, corrosion, injury and/or death, and loss of revenue or profit. The manufacturer will void all warranties specific or implied.

All claims must be discussed with an authorized representative of the manufacturer prior to any repairs, or warranty will be void. Recommended repairs and costs are to be discussed with and agreed upon in advance by manufacturer's representative. Repair or labor (at an agreed rate) will be performed by a manufacturer's specified dealer, and at a repair shop designated by the manufacturer. The repair or replaced product shall be guaranteed for the applicable warranty's remaining period. All shipping costs associated with any repairs are the customer's responsibility.

### IMPORTANT

Fill out & save this section for your records

Date Purchased:	
Model Purchased:	
Serial Number:	

Dealer Name:	
Dealer Address:	
Dealer Phone#:	

# WHY SNOW CONTRACTORS TRUST ARCTIC

WE DEVELOP PRODUCTS FOR THE SERIOUS CONTRACTOR BECAUSE WE ARE A SERIOUS CONTRACTOR

Arctic Snow and Ice Products is the only major snow products manufacturer that is also one of the largest snow contractors in America, with over 40 years of experience. With over 450 light and heavy duty loaders, skid steers and salt trucks, Arctic owns the nation's largest self operating fleet. That is why you know that before any of our products go to market, we have tested them thoroughly in the real world conditions of bitter Chicago winters.

Our Arctic Sectional Sno-Pusher™ leads the industry in efficiency, maintainability, safety and value — and pays for itself in its first season of use. That's how we built it — that's why we use it! We are proud to say that we only build what we use, and we only use what we build. Uncompromising quality for uncompromising weather...that's Arctic.



# GETTING TO KNOW YOUR RAZORBACK RETROFIT KIT™

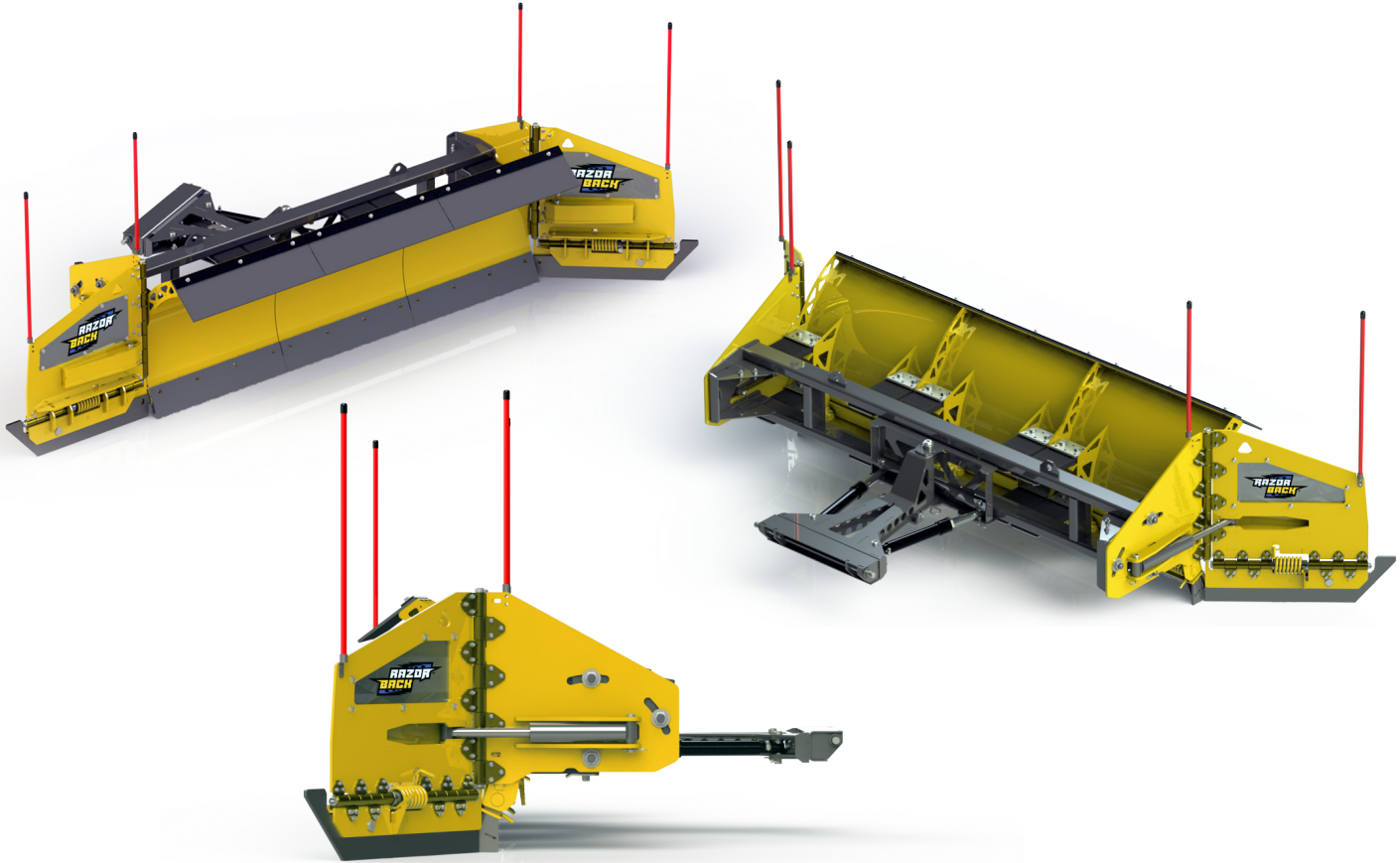

## Arctic Sectional Technology

- ★ Independent sectional moldboards
- ★ Forgiving, impact absorbing polyblock design
- ★ AR400 spring-loaded trip cutting edges

## Free Floating Wings

- ★ Hydraulically adjustable between transport, plow and scoop mode
- ★ Floating - AR400 spring-loaded tripping cutting edge on each wing, that conform to the pavement and scrapes to the ground.
- ★ Designed to trip over obstacles such as curbs and manhole covers

## Designed to Last

We understand that things go wrong. Every part of the RazorBack has been designed to be fully replaceable. Never again will you hit something and have to write off the entire plow.



## POLYBLOCKS: WHAT THEY DO & WHY WE USE THEM

Critical to the design performance of the Arctic Sectional Sno-Pusher™ are the polyurethane mounting blocks that allow the individual sections to move up and down, contour to uneven road surfaces and avoid collision damage. Furthermore, they flex to allow an operator to apply thousands of pounds of additional down pressure, if desired, directly to the cutting edge, allowing it to scrape up ice and hardpacked snow as if it were powder, something that heavy duty springs cannot do. This technology is patented and exclusive to Arctic.

The “polyblocks” as they are called also provide a unique safety benefit to the operator and to the pusher in that they are designed to buffer impact damage that would normally be severe enough to damage the overall integrity of the pusher. Under those circumstances, one or more polyblocks will act like fuses and absorb all of the punishment breaking, if necessary, in order to protect more costly metal components or the frame itself. The level of damage avoided would be enough to bend the main moldboard or frame of a traditional pusher, making the cost of replacing a broken polyblock in that instance a far more desirable solution. Please note that the formula that is used for Arctic’s polyurethane blocks is proprietary and was developed over several years. Using aftermarket polyblocks on your Arctic Sectional can lead to damaging results and will void your warranty.



**Please report any Arctic dealer that is selling aftermarket parts or suggesting the use of aftermarket parts.**

*Arctic Snow and Ice Products® is in no way endorsed by or associated with Boss Snowplow, Douglas Dynamics, Fisher Products or Western Products. The Arctic RazorBack Retrofit Kit™ is an aftermarket retrofit kit designed to work with the BOSS® EXT™, Fisher® XLS™ and the WESTERN® WIDE-OUT™ XL hardware. The Arctic Razorback Retrofit Kit™ is not endorsed by or associated with Boss Snowplow, Douglas Dynamics, Fisher Products or Western Products.*



# SAFETY PRECAUTIONS & WARNINGS

Read and understand this Owner's Manual before installing, operating, or making adjustments to the RazorBack Retrofit Kit™. Improper installation and operation could cause personal injury (to operator and bystanders) and/or equipment and property damage.

## GENERAL

**ALWAYS** be sure to keep hands, feet, hair, and clothing away from pinch points/moving parts.

**ALWAYS** keep the plow on the ground when parked or not in use.

**ALWAYS** inspect your plow for wear and damage before operating.

**NEVER** place any part of your body under the plow.

**NEVER** use the RazorBack Retrofit Kit™ for ANY purpose other than plowing snow. Doing so could result in serious injury or death. It will also void your warranty.

**NEVER** alter the plow in any way.

## DURING OPERATION

**ALWAYS** operate the plow at the recommended speed.

**NEVER** plow while the plow is in "Transport Mode".

**NEVER** stand or sit on the plow while it's in operation.

**NEVER** stand in front of a plow while truck is in operation.

## MAINTENANCE / SERVICING

**ALWAYS** use Arctic OEM replacement parts.

**ALWAYS** take a few minutes to properly secure your plow using jack stands to ensure safety during maintenance/service.

**NEVER** attempt to service this plow, unless you know how to do it safely and have the proper tools for the job.

**NEVER** service or otherwise handle a plow in the raised position unless it is securely blocked against unexpected falling.

**NEVER** rely solely upon the hydraulics of your machine to secure the plow during maintenance/service.

**NEVER** get under the unit during maintenance procedures without properly securing the plow.

Safety decals must not be removed. If damaged, they must be replaced.

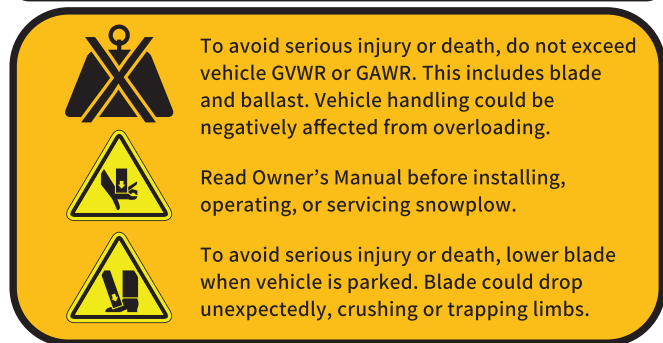

# SAFETY PRECAUTIONS & WARNINGS

**STOP!** Read disclaimer below before operating your RazorBack Retrofit Kit™

Before normal operation, bolts for the wing hinge are required to be torqued to 37 ft-lbs, and bolts for trip edge are required to be 22 ft-lbs. Failure to do so may result in damage to the plow wing.

## WING HINGE

Before operating, make sure that all of the bolts and nuts circled are torqued to 37 ft-lbs.



## WING TRIP EDGE

Before operating, make sure that all of the bolts and nuts circled are torqued to 22 ft-lbs.



*Arctic Snow and Ice Products® is in no way endorsed by or associated with Boss Snowplow, Douglas Dynamics, Fisher Products or Western Products. The Arctic RazorBack Retrofit Kit™ is an aftermarket retrofit kit designed to work with the BOSS® EXT™, Fisher® XLS™ and the WESTERN® WIDE-OUT™ XL hardware. The Arctic Razorback Retrofit Kit™ is not endorsed by or associated with Boss Snowplow, Douglas Dynamics, Fisher Products or Western Products.*

# WHAT'S INCLUDED

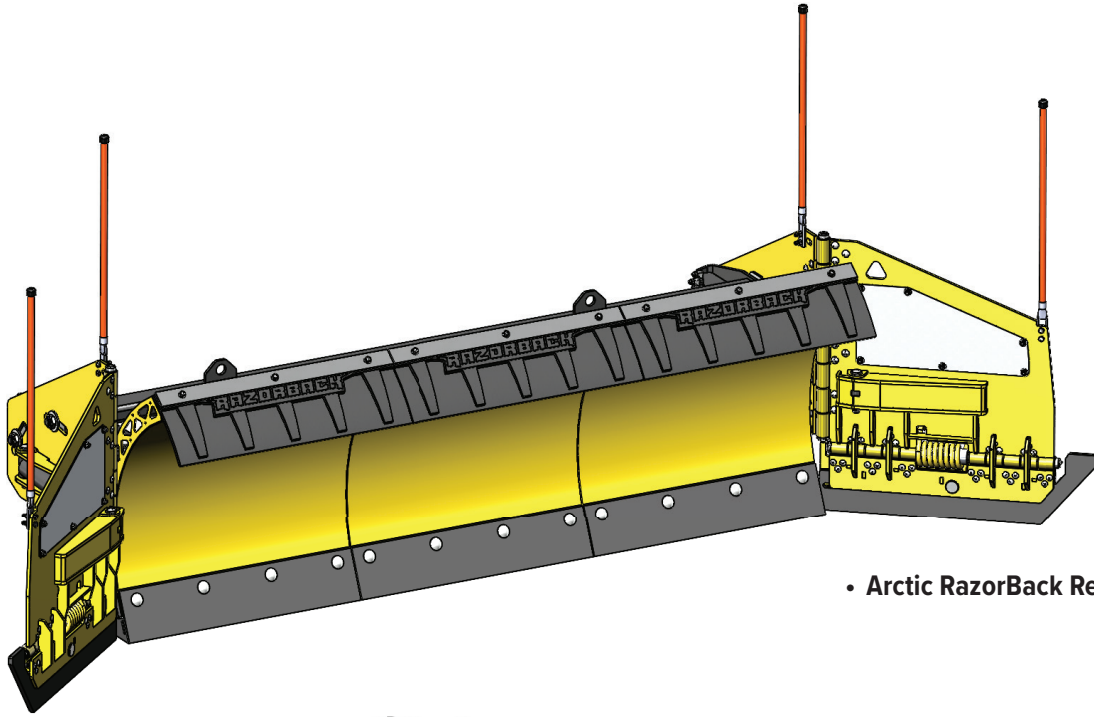

• Arctic RazorBack RetroFit Plow™ x1

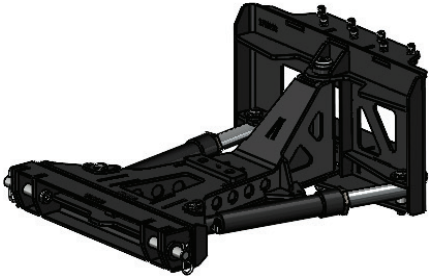

• A-Frame Assembly (if ordered unassembled)



• Snow Deflector Boss Plates & Hardware x3

• Snow Deflectors x3



• Plow Guides & Hardware x4



# RAZORBACK RETROFIT PLOW™ COMPONENTS

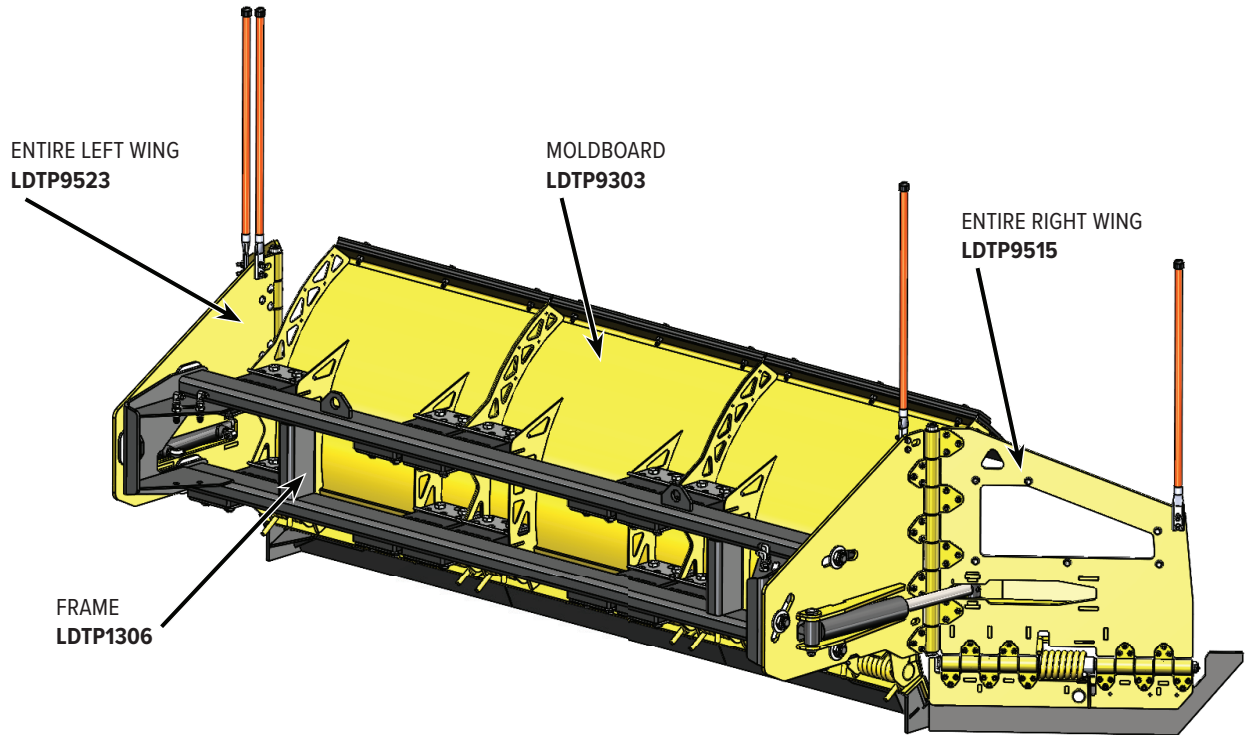
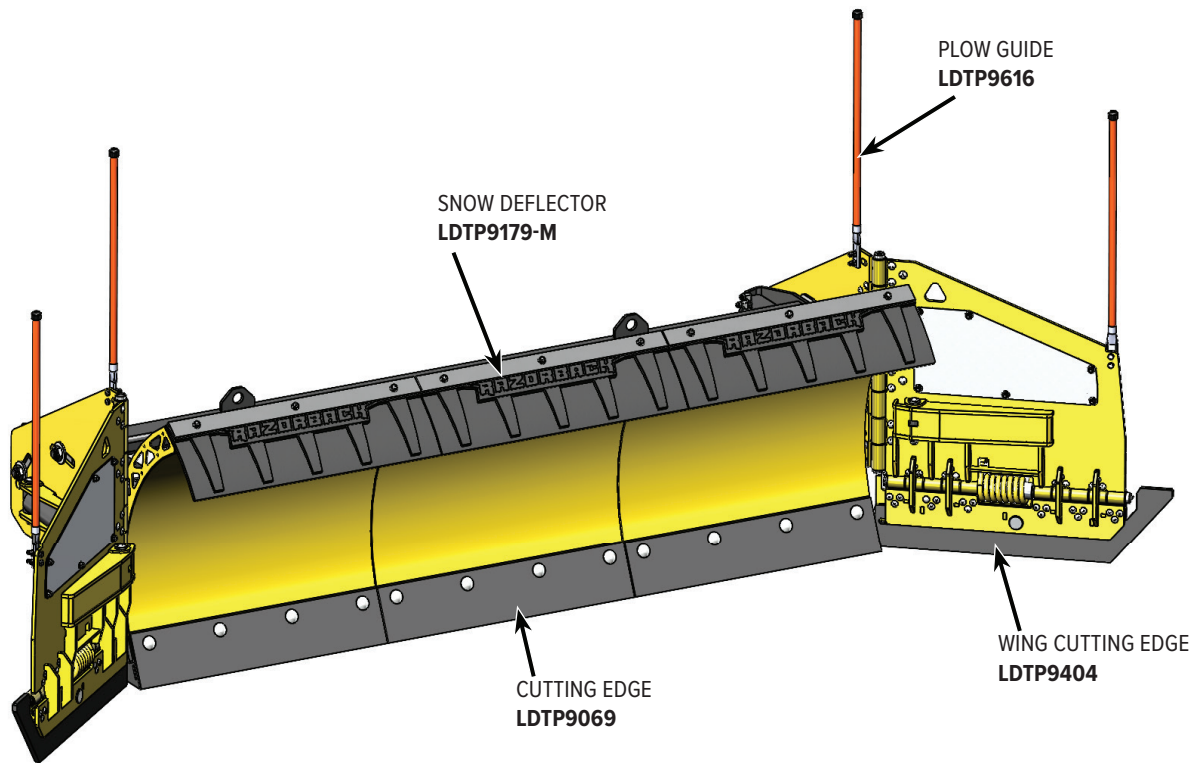

Arctic Snow and Ice Products® is in no way endorsed by or associated with Boss Snowplow, Douglas Dynamics, Fisher Products or Western Products. The Arctic RazorBack Retrofit Kit™ is an aftermarket retrofit kit designed to work with the BOSS® EXT™, Fisher® XLS™ and the WESTERN® WIDE-OUT™ XL hardware. The Arctic Razorback Retrofit Kit™ is not endorsed by or associated with Boss Snowplow, Douglas Dynamics, Fisher Products or Western Products.

# WING TO FRAME

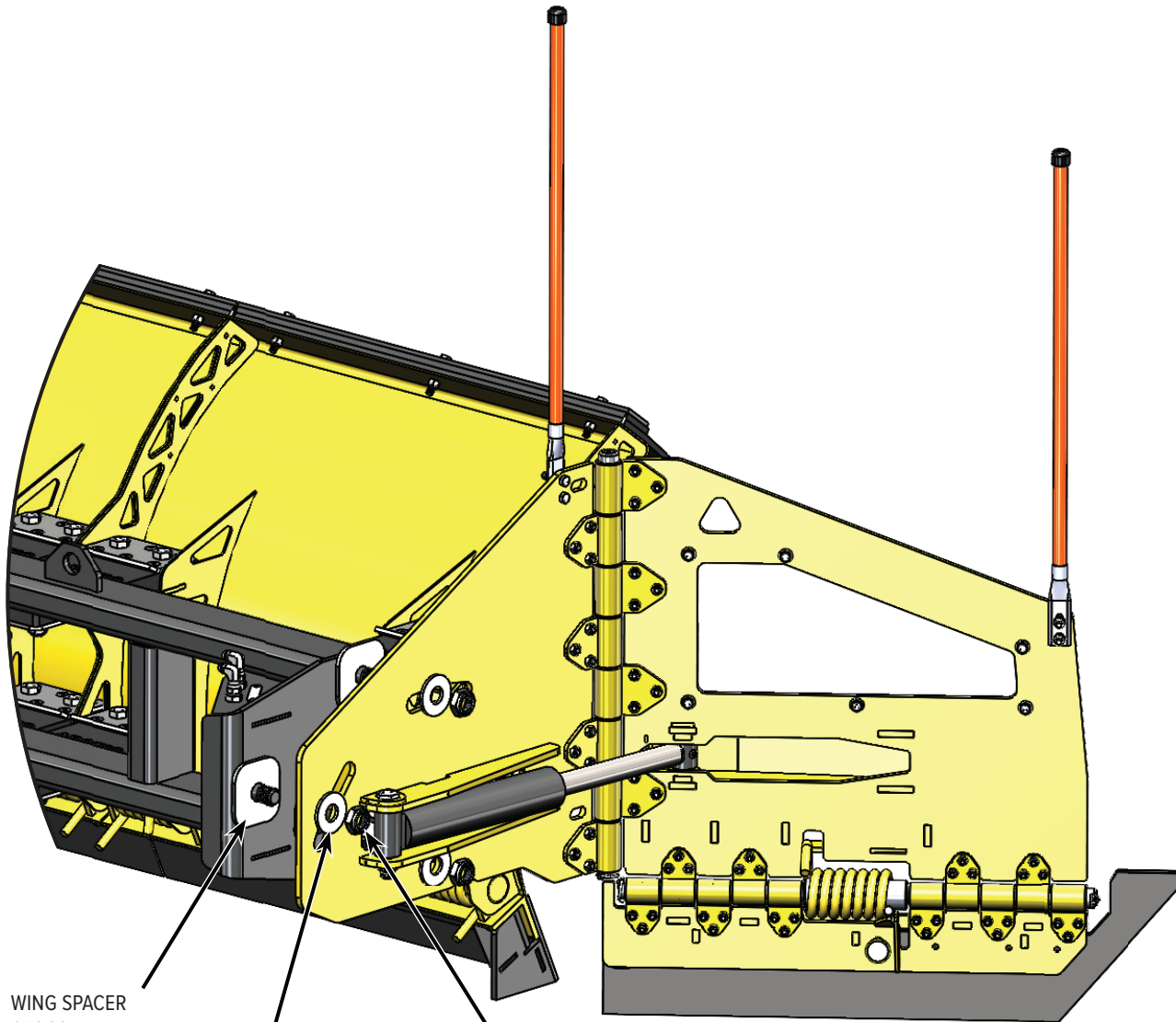

WING SPACER  
07068

WING WASHER  
SPAWLD9082

WING NUT (1-8 Shallow Nylon Locknut)  
SPAWLD9080

 Until tight, then back off until loose

 = Torque Symbol



# WING COMPONENTS

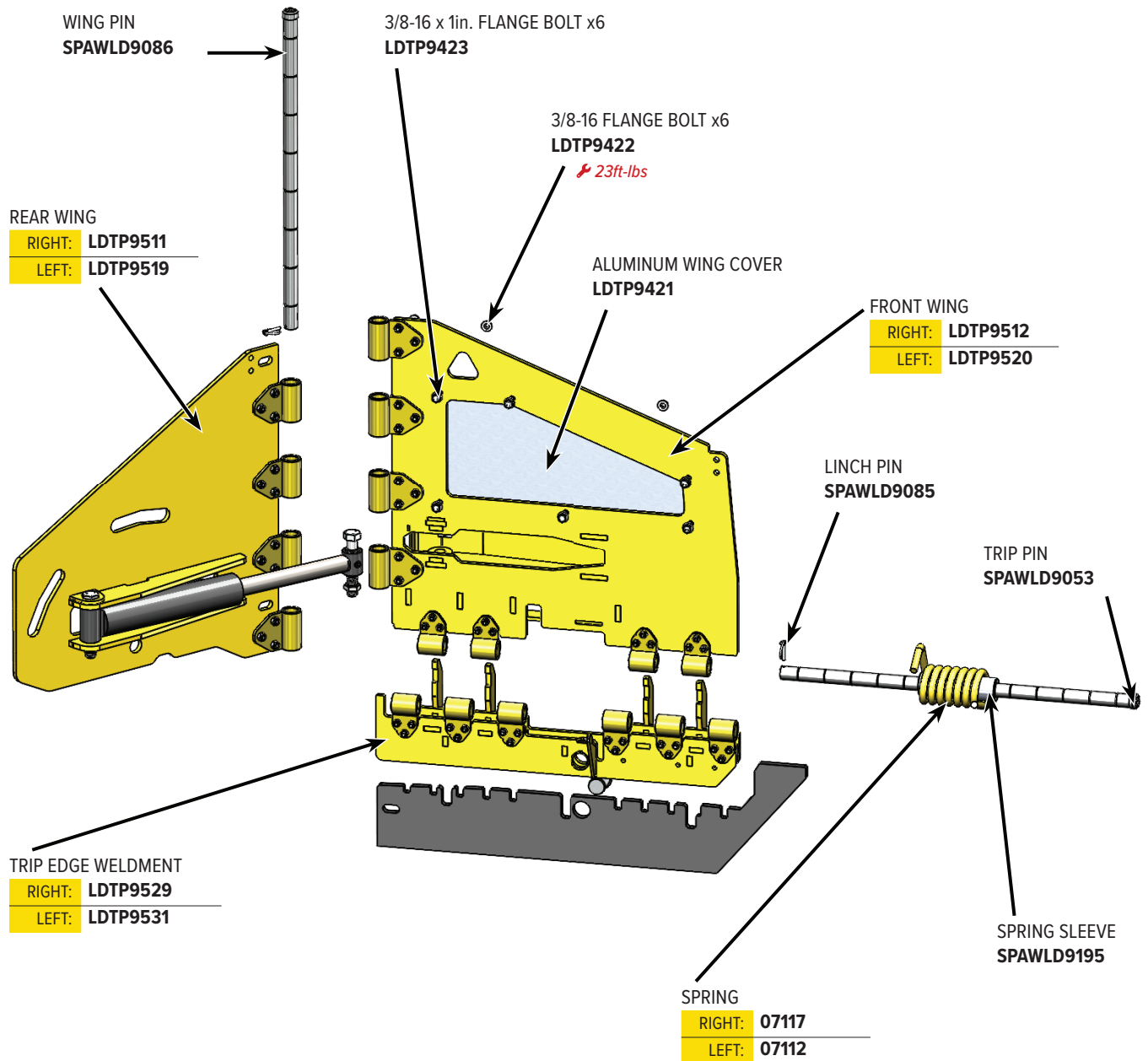

⚡ = Torque Symbol

Arctic Snow and Ice Products® is in no way endorsed by or associated with Boss Snowplow, Douglas Dynamics, Fisher Products or Western Products. The Arctic RazorBack Retrofit Kit™ is an aftermarket retrofit kit designed to work with the BOSS® EXT™, Fisher® XLS™ and the WESTERN® WIDE-OUT™ XL hardware. The Arctic Razorback Retrofit Kit™ is not endorsed by or associated with Boss Snowplow, Douglas Dynamics, Fisher Products or Western Products.

# WING COMPONENTS

3/4-10 x 4.5in. HEX HEAD BOLT  
LDTP9473

FRONT WING CYLINDER SLEEVE  
LDTP9471

3/4-10 SHALLOW NYLON LOCK NUT  
LDTP9469  
🔧 145ft-lbs

WING CYLINDER  
LDTP9402

WING CYLINDER FITTINGS  
SPAWLD9166

REAR WING CYLINDER SLEEVE  
LDTP9470

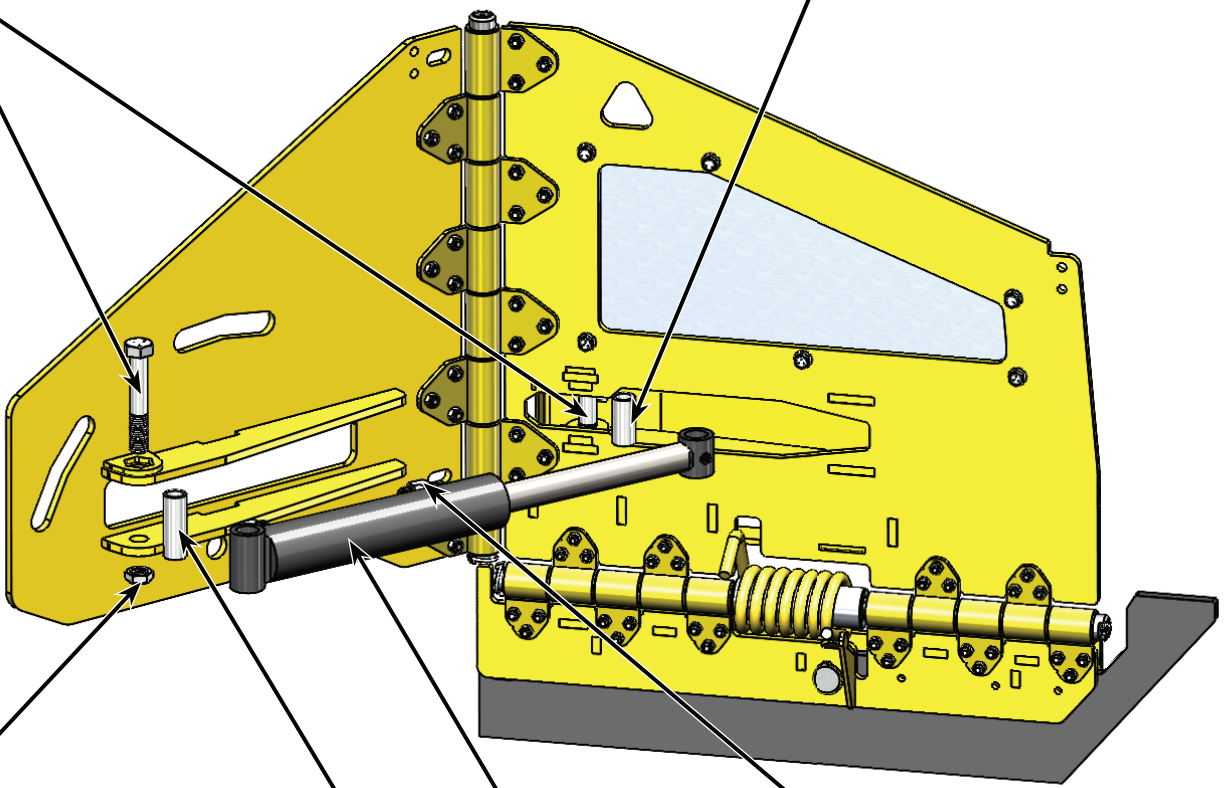

🔧 = Torque Symbol



# WING COMPONENTS

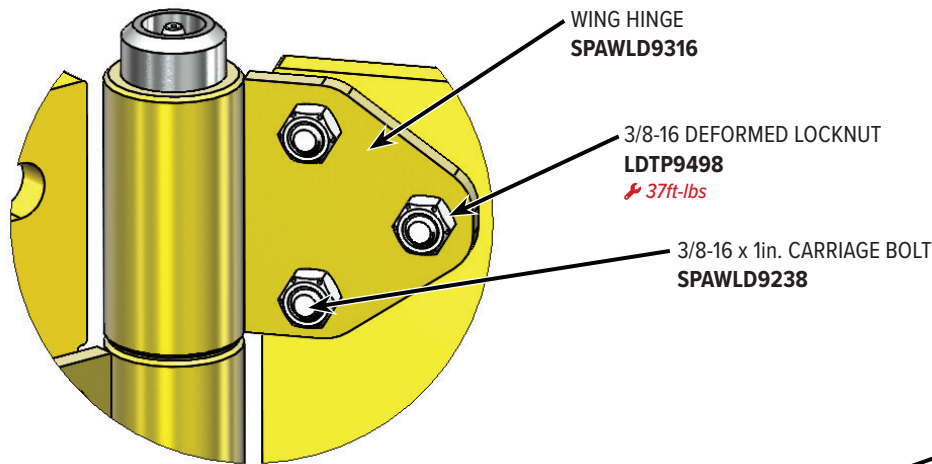

**DETAIL A**  
SCALE 1:2

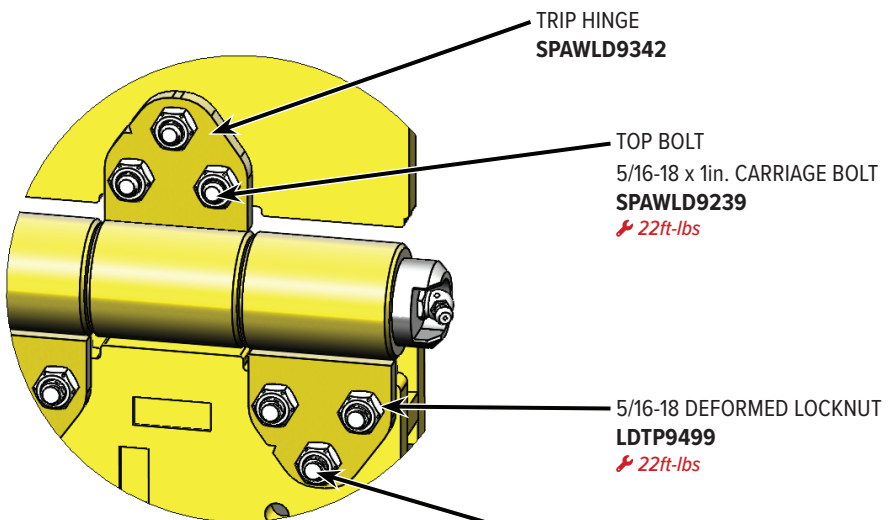

**DETAIL B**  
SCALE 1:2

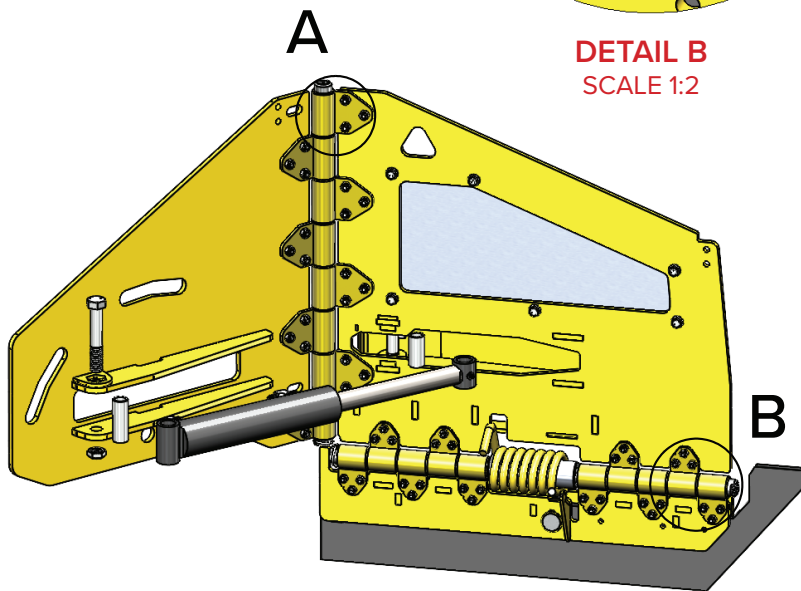

 = Torque Symbol

Arctic Snow and Ice Products® is in no way endorsed by or associated with Boss Snowplow, Douglas Dynamics, Fisher Products or Western Products. The Arctic RazorBack Retrofit Kit™ is an aftermarket retrofit kit designed to work with the BOSS® EXT™, Fisher® XLS™ and the WESTERN® WIDE-OUT™ XL hardware. The Arctic Razorback Retrofit Kit™ is not endorsed by or associated with Boss Snowplow, Douglas Dynamics, Fisher Products or Western Products.



# WING COMPONENTS

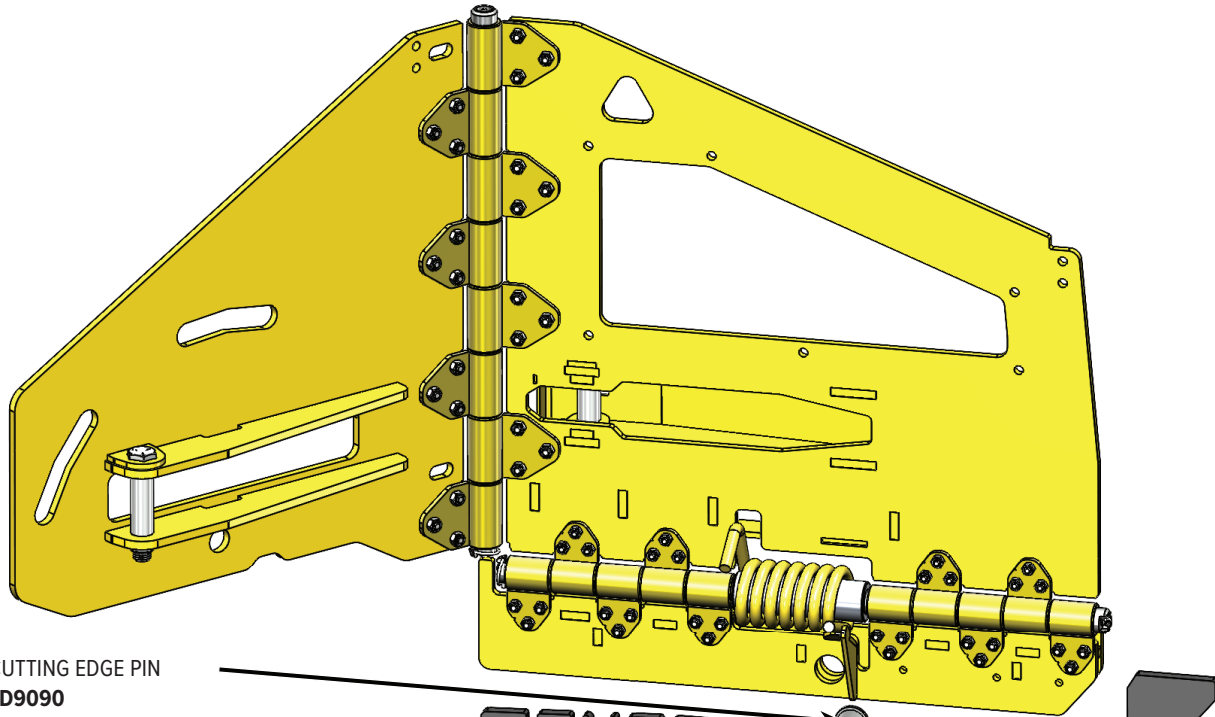

WING CUTTING EDGE PIN  
SPAWLD9090

WING CUTTING EDGE  
LDTP9404

C-CLIP  
SPLD1.59060



# MOLDBOARD ASSEMBLY

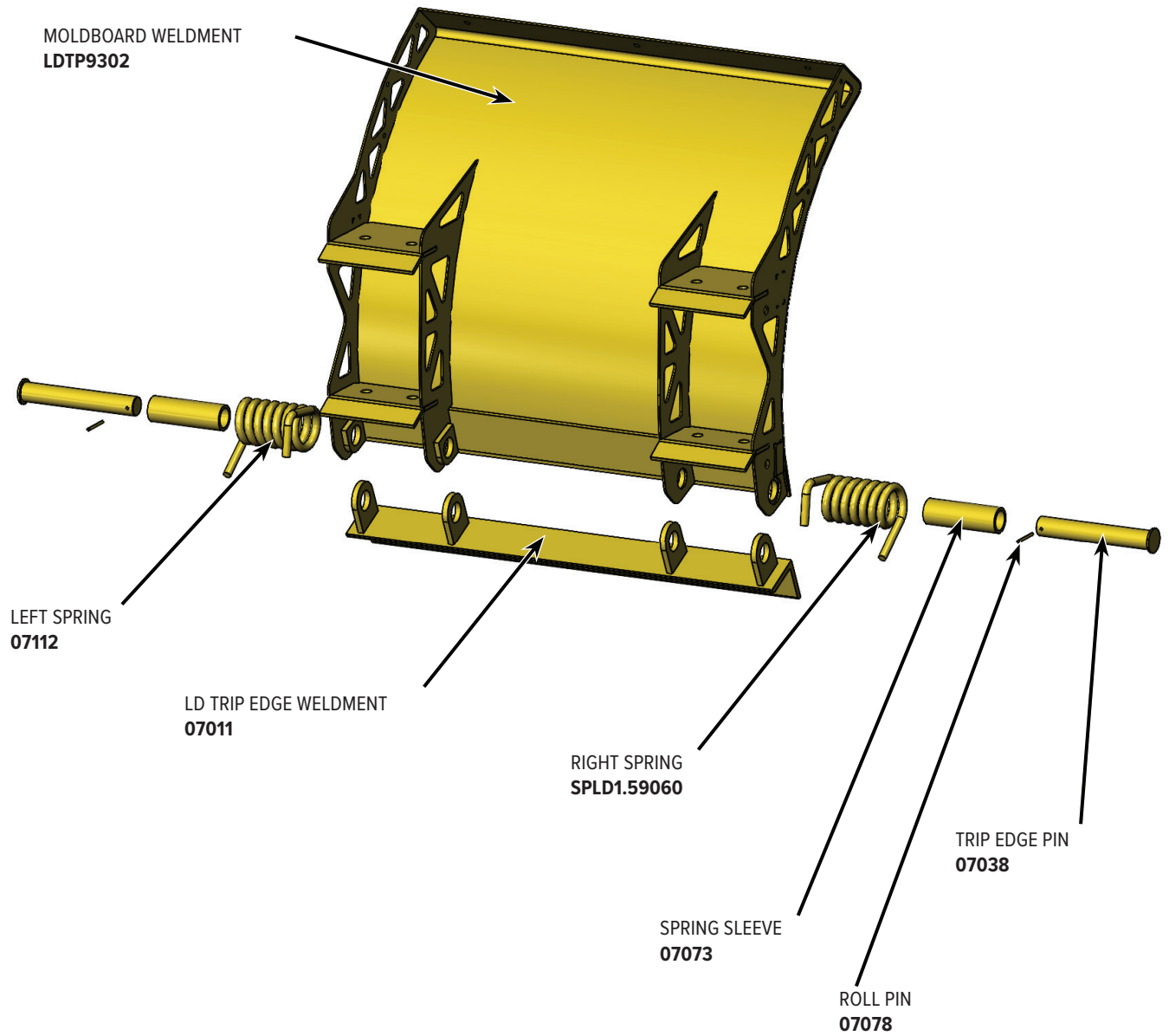

*Arctic Snow and Ice Products® is in no way endorsed by or associated with Boss Snowplow, Douglas Dynamics, Fisher Products or Western Products. The Arctic RazorBack Retrofit Kit™ is an aftermarket retrofit kit designed to work with the BOSS® EXT™, Fisher® XLS™ and the WESTERN® WIDE-OUT™ XL hardware. The Arctic Razorback Retrofit Kit™ is not endorsed by or associated with Boss Snowplow, Douglas Dynamics, Fisher Products or Western Products.*

# CUTTING EDGE & SNOW DEFLECTOR TO MOLDBOARD

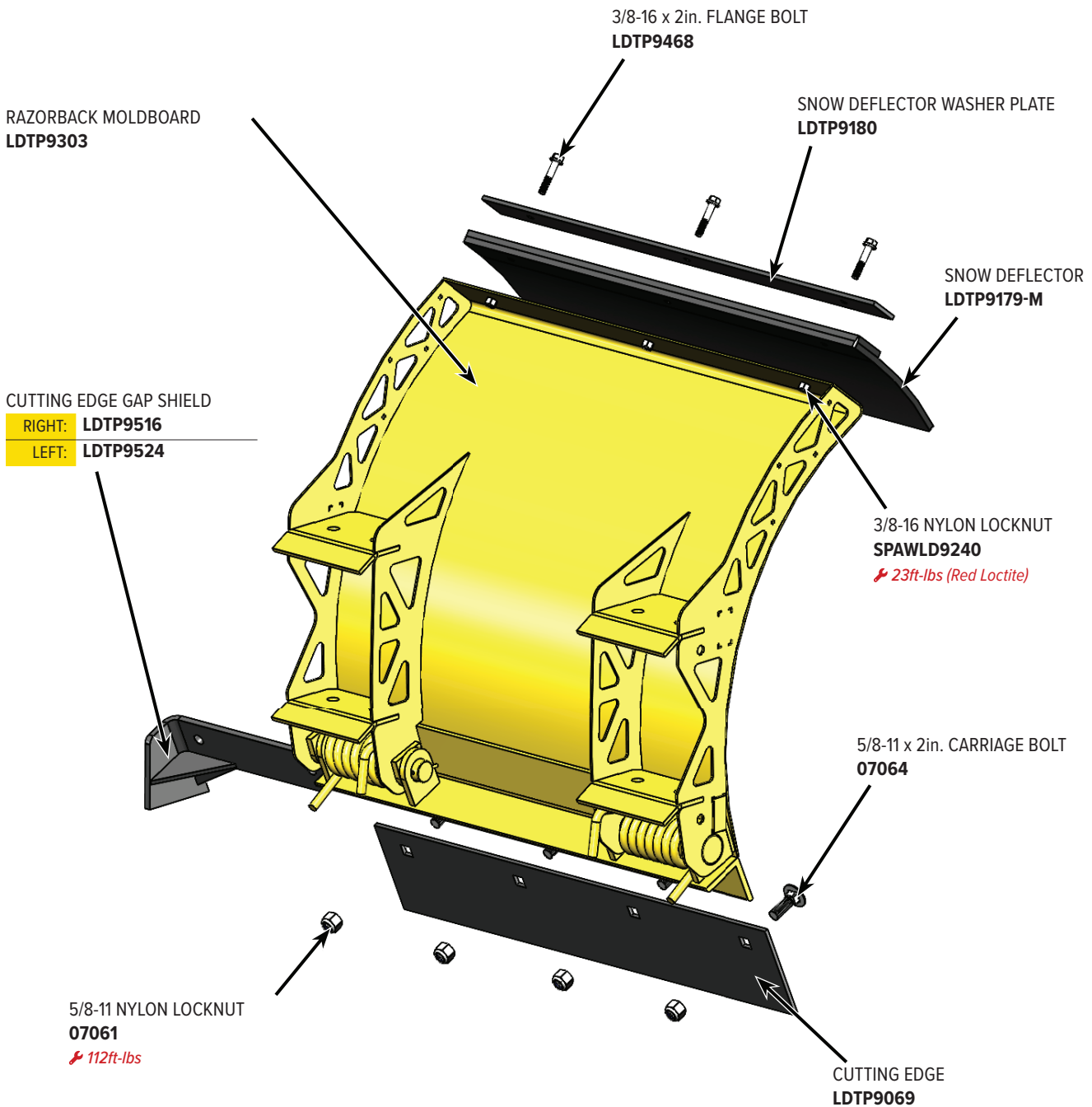

⚙️ = Torque Symbol



# MOLDBOARD TO FRAME

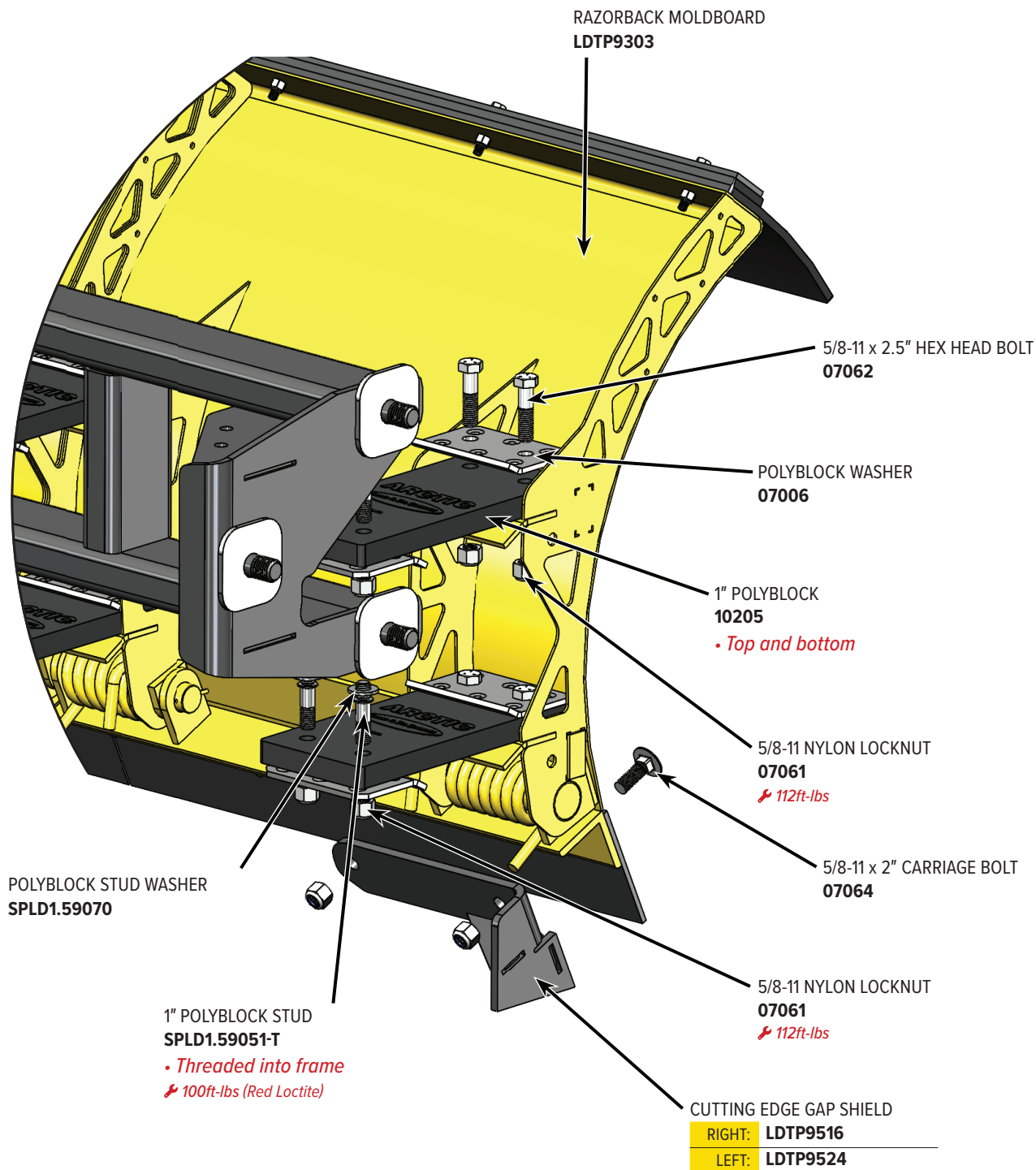

🔧 = Torque Symbol

Arctic Snow and Ice Products® is in no way endorsed by or associated with Boss Snowplow, Douglas Dynamics, Fisher Products or Western Products. The Arctic RazorBack Retrofit Kit™ is an aftermarket retrofit kit designed to work with the BOSS® EXT™, Fisher® XLS™ and the WESTERN® WIDE-OUT™ XL hardware. The Arctic Razorback Retrofit Kit™ is not endorsed by or associated with Boss Snowplow, Douglas Dynamics, Fisher Products or Western Products.

# A-FRAME PARTS LIST for a BOSS® EXT™

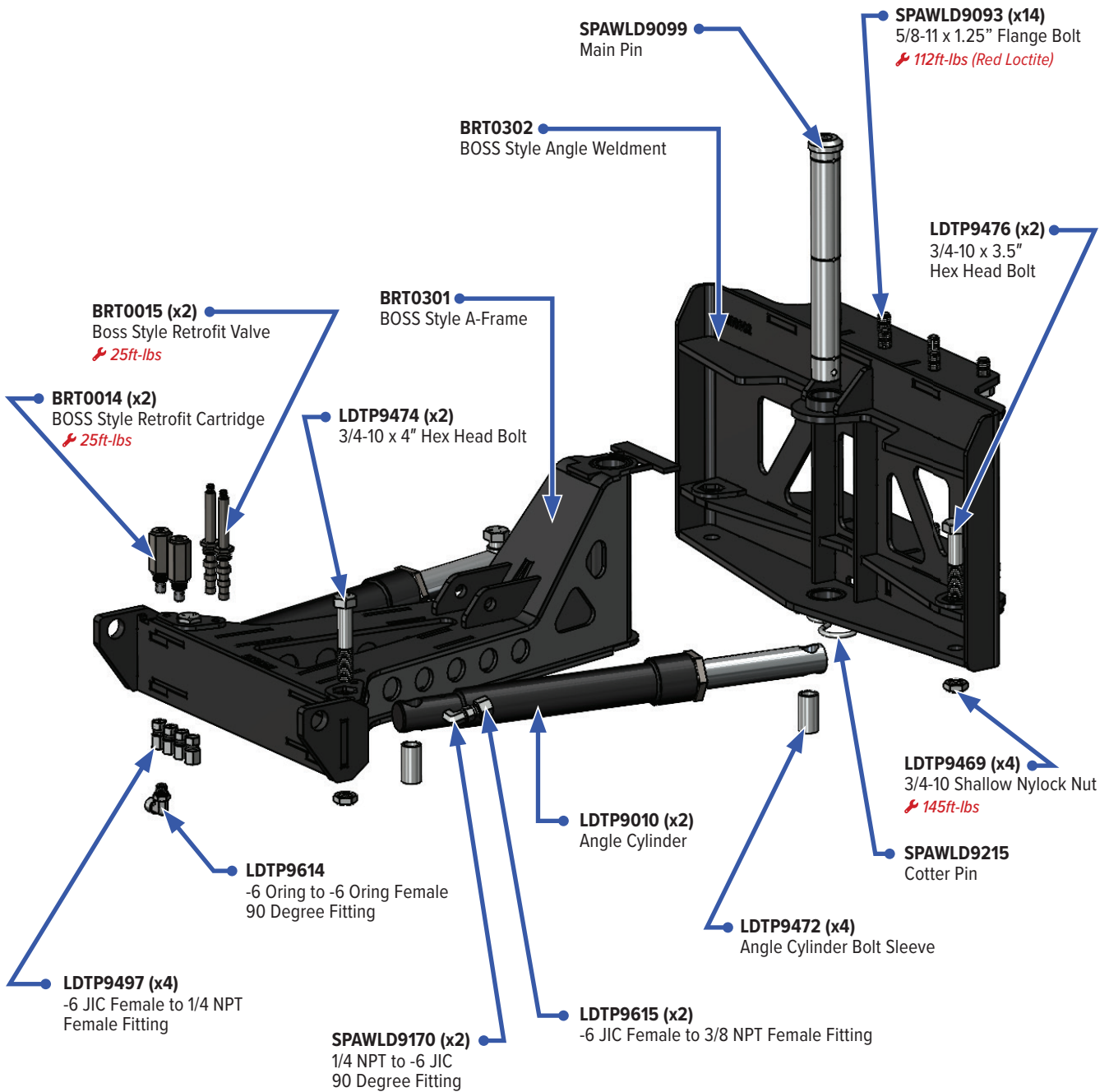

⚡ = Torque Symbol



# A-FRAME PARTS LIST for a FISHER® XLS™

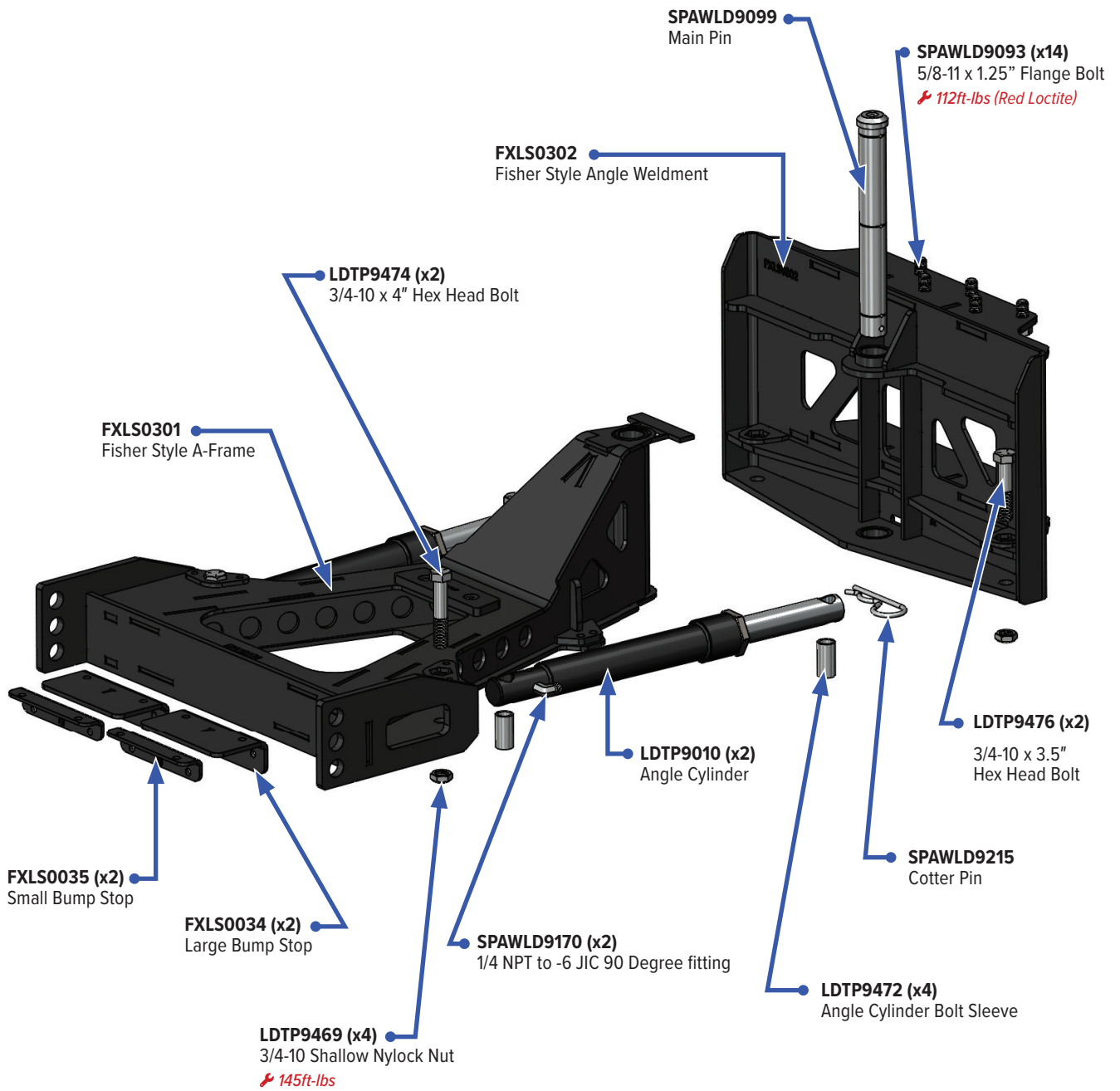

⚙️ = Torque Symbol

Arctic Snow and Ice Products® is in no way endorsed by or associated with Boss Snowplow, Douglas Dynamics, Fisher Products or Western Products. The Arctic RazorBack Retrofit Kit™ is an aftermarket retrofit kit designed to work with the BOSS® EXT™, Fisher® XLS™ and the WESTERN® WIDE-OUT™ XL hardware. The Arctic Razorback Retrofit Kit™ is not endorsed by or associated with Boss Snowplow, Douglas Dynamics, Fisher Products or Western Products.

# A-FRAME PARTS LIST for a WESTERN® WIDE-OUT™ & WIDE-OUT XL

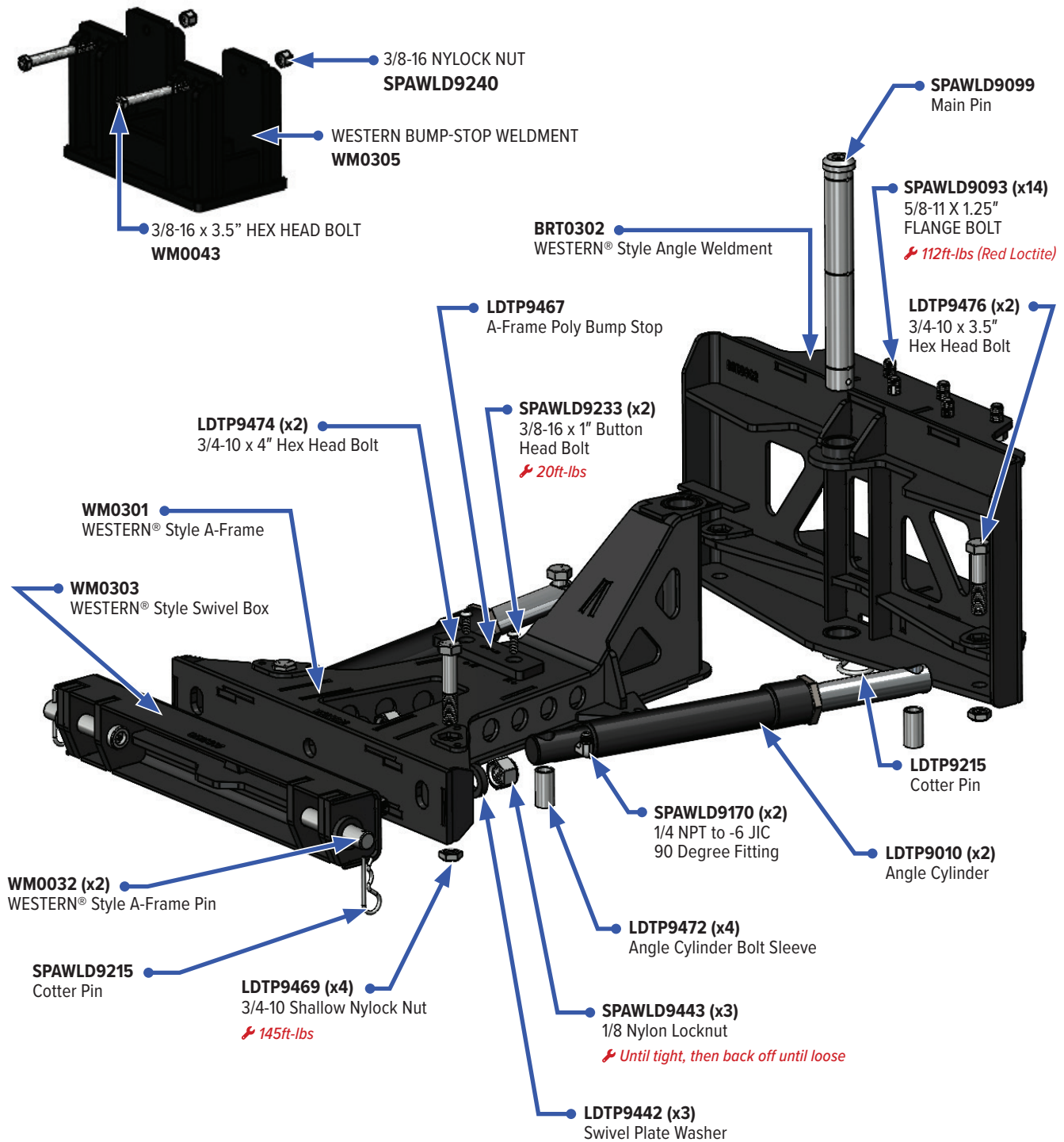

🔧 = Torque Symbol



# INNOVATING AN INDUSTRY™



Scan the code to view  
this document and other  
support materials online.

